

Structured Modeling Technology: A Modeling Environment for Integrated Environmental Assessment

W. Purwasih^a and Y. Nakamori^a

^a *Japan Advanced Institute of Science and Technology, 1-1 Asahidai, Tatsunokuchi, Japan,*

Abstract: Sound environmental decision-making and assessment require integration of modeling resources such as models and complex tools, large volumes of often disparate and multi-format data from numerous sources and effective methods of disseminating and presenting results that allow broad, interactive participation in the assessment and decision-making process. This paper discusses how data sets, models and modeling tools are incorporated into the design of a structured modeling environment. In this paper, we describe the background and implementation of structured modeling environment, which was developed to facilitate and integrate many aspects of the modeling process. The conceptual framework underpinning the structured modeling technology identifies the major aspects of integration between database management system, models, tools, object oriented paradigm, XML and Web technology to provide some of the elements to effectively support Integrated Environmental Assessment (IEA). It helps lay the foundation for the development of implemented prototype using AIM/Trend model to meet the requirements of modeling activities for supporting IEA in Asia Pacific region.

Keywords: Modeling environment; Structured modeling; Structured modeling technology; IEA

1. INTRODUCTION

Integrated Environmental Assessment (IEA) is increasingly recognized as an important technique for managing the environmental impacts of human actions. Therefore, producing accurate assessments of both the state of environment and the consequences of environmental policies becomes critical for effective decision-making. Integrated environmental assessment requires knowledge and understanding of nature and trends in characteristics of complex environmental processes. Because the pertaining phenomena in environmental problems are typically multidimensional, it may require drawing causal inferences from knowledge and data that are combined from different disciplines. Hence, efforts to develop responses to the complex of global environmental change have created the need for access to communication networks, individual and organizational expertise, and types of computerized modeling resources such as data sets, models, solvers, and tools.

Modeling has the potential to provide decision makers and others involved in environmental assessment with tools that enhance understanding of their natural system and the interactions

between system components, and allow 'what-if' scenario testing of environmental policies based on strategies and environmental conditions [Dolk, 1993; Makowski, 2004; Rizolli et al., 1998; Wierzbicki et al., 2000]. Due to the interdisciplinary nature and complexity of environmental problems, IEA requires the use of a variety of modeling approaches that can be coupled together to adequately address all elements of a given problem. This needs to include both individual system components and broad system interactions. An integrated model that will allow comparison of the effects of suggested actions, and various combinations of actions, provides a tool not only for option analysis, but also for redirecting debate from a finger-pointing approach to constructive dialogue, thereby facilitating progress towards policy consensus. The Club of Rome has initiated the use of integrated modeling and later various models explicitly addressed environmental issues emerged in the late 1970s.

While the advantages of modeling have been articulated for some time, the development of integrated environmental models that are actually used by assessment is no simple task. Attempts in the development of integrated models have been

hampered by a number of problems. 'Integration' will require the diverse range of modeling paradigms to enhance modeling process (e.g. specification, analysis and documentation). Furthermore, the process of model formulation and subsequent integration of model with data in a system is a complex and ill-structured process [Parker et al., 2002]. Due to incompatible modeling representation and data handling used by each modeling paradigm, it is difficult to simply link the corresponding modeling resources. Another issue that has been emphasized by Parson [1995] and Parker et al. [2002] is the requirement of appropriate communication that could facilitate the involvement of stakeholders on model results and the detailed needed for developing alternative strategies.

It is noted in Geoffrion [1989] and Dolk [1993] that structured modeling, as a lingua franca, can be used widely in many different applications, and therefore simplify modeling resources integration. However, it should be extended to address the wider issues of model sharing and multiple users that allow wide participatory in modeling process. Learning from the previous work [Dolk, 1993; Kokkonen, 2003; Rizzoli, 1998], in this paper we attempt to report our ongoing work on incorporating modeling resources for environmental assessment using Structured Modeling Technology [Makowski, 2004]. In the work described here, we use Structured Modeling Technology (SMT) that adopt Geoffrion's structured modeling approach as the vehicle for model representation to provide some of the elements of an integrated modeling environment in such a manner that subcomponents of the system would be reusable and adoptable to others similar modeling process. This modeling technology combines database management system, object-oriented programming, XML and Web technology to promote integration and collaboration in solving complex environmental problems.

The rest of this paper is organized as follows. Section 2 gives the formal description of AIM model as an example of integrated models that was developed to meet the requirements of modeling activities for supporting Integrated Environmental Assessment in Asia Pacific region. Section 3 provides some background knowledge of structured modeling. The platform for integrated modeling environment using structured modeling is explained in Section 4. Section 5 presents implementation issues using structured modeling technology. Finally, some concluding remarks are briefly discussed in Section 6.

2. AIM: AN EXAMPLE OF INTEGRATED MODELS

Here we describe briefly the AIM model that is used in our work. The EIA sub-project of APEIS (Asia-Pacific Environmental Innovation Strategy Project) has provided a set of computer models and database that can be used to analyze the impacts of climate change and mitigation policies for the region. By using the AIM modules and databases, policy/decision makers in the region will be able to develop the most appropriate innovation strategies for specific socio-environmental problems in their countries, taking into account local social, economic and environmental conditions.

The Asia-Pacific Integrated Model (AIM) has been developed by National Institute of Environmental Studies Japan as tool for assessing policy options on sustainable development particularly in the Asia-Pacific region. For this purpose, six models have been developed based on the AIM's family, those are, AIM/Trend, AIM/CGE, AIM/Material, AIM/Energy, AIM/Ecosystem, and AIM/Water. AIM has been used by Intergovernmental Panel on Climate Change (IPCC) as one of models used to develop SRES scenarios [IPCC, 2000].

Aim/Trend, which was developed to predict the economic, energy and environmental trend in 42 countries in Asia-Pacific region, uses simple-econometric method and develops several scenarios for capacity building [Kainuma *et al.* 2003]. This model consists of two sub-models, Model A and Model B, and it has been developed based on the availability of energy balance's data in IEA. In Model A, five scenarios were prepared: Reference, Market First scenario, Policy First scenario, Security First scenario, and Sustainability First scenario. An overview of the structure of Model A is given in Figure 1.

3. STRUCTURED MODELING AS PLATFORM FOR INTEGRATED MODELING ENVIRONMENT

Structured Modeling was originally developed by Arthur M. Geoffrion [1987] in order to identify the basic components of models, the relationships among these components, and conditions under which a model may be termed "structured". It is applied in order to enhance and facilitate some essential functions like model prototyping, data and model access, and model integration.

There are three basic structures: (i) *elemental*, (ii) *generic* and (iii) *modular*. A "structured model"

can be defined as an elemental structure which may be partitioned into genera and further aggregated into modules. Here we summarize some general definitions and for more detail explanation please refer to [Geoffrion, 1987; Geoffrion 1989].

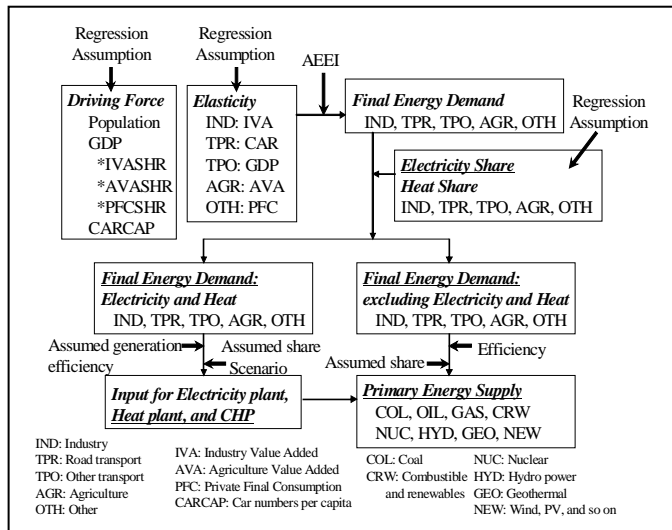

Figure 1. Calculation flow of Sub-model A [Kainuma, 2003]

Elemental structure consists of: primitive entity, compound entity, attribute, function and test. Primitive entities represent things or concepts and require no value. Compound entities represent other things or concepts and have no associated value. Attributes represent properties of things or concepts and have a constant value. Variables attributes are attributes whose values unspecified. Function elements represent calculable properties or mathematical equations and its value depends on a rule and the values of called elements. Test elements are function elements with a Boolean (True, False) value and it can be used to specify constraints in mathematical models. Elemental structure can be represented in terms of a directed graph of elements and "calls". A nonempty, closed, finite, and acyclic collection of elements must be satisfied by the elemental structured of a model.

A *generic structure* represents a partitioning of the elemental structure into genera, such that there is one genus for each element type. It must satisfy generic similarity in that every element in a genus calls elements in the same foreign genera. A tree defined on the generic structure all of whose leaves are genera, and all of whose non-terminal nodes are modules is defined as a *modular structure*. It should satisfy the

qualification, which is called monotone. A model can be defined as a structured model if it consists of an elemental structured, a generic structure satisfying similarity, and a monotone modular structure.

Structured modeling does not deal with inputs and/or outputs explicitly. Input variables in structured modeling will usually be designated as fixed attribute (*a*) elements although it's conceivable that primitive entity (*pe*) elements could be inputs. Model outputs usually will be either variable attribute (*va*) or function (*f*) elements. Structured modeling extends semantic data models from the database world to capture the complexities of mathematical modeling. It allows the user to view models graphically, textually, or algebraically, and at different levels of abstraction. Hence, a new modeling environment based on structured modeling will be discussed in the next section.

4. THE REQUIREMENT OF MODELING ENVIRONMENT FOR IEA

Recently, a number of proposals have been made for achieving the desired level of integration between modeling resources. The notion of modeling paradigm integration arose from the issue of model representation coupled with data, tools and solver integration. Model integration, which characterized by linking various constituent modules, typically carries with it the requirement of solver integration as well since different models usually involve distinct solver technologies. A solver is defined as a method or program to manipulate a model and always paired with a model class, modeling paradigm or modeling tradition. Reliable assessments require not only models and modeling tools (e.g. visualization and various analytical tools) but also valid data that are required to populate a meaningful model instance. Environmental data sets are large and often complex. To maintain vast amount of computer-stored data, a database management system is commonly used. Therefore, the integration of databases and models that allows users to automatically retrieve and load input data for complex models is essential.

As computer-processing power has become more affordable, integrating (sub-) models, tools, solvers, and data sets into integrated modeling environment is a challenging task. A number of conventional modeling systems which successfully assimilate innovations like spreadsheets and

relational databases still involve a good deal of inefficiency because it could not satisfy one or more the below requirements.

An integrated modeling environment has been rephrased [Geoffrion, 1989] to capture a broader notion of integration; not just integration of models and data but also integration of software tools (solvers, DBMS, GUI, etc.) as well. The required characteristics particularly could be categorized into: (i) support for models, (ii) support for solvers, and (iii) utilities (tools). Similarly, Brandmeyer [2000] defines that an overall modeling framework should provide functions and tools common to multiple models, while managing data and computing resources using a single GUI to the modeler and implementing shared data storage.

Therefore, the development of modeling environment for integrated environmental assessment should fulfill the requirement for:

- Providing context for integrated environmental assessment;
- Support for analyzing the cause-effect relationships of a specific environmental issue. It should cover a wide range of analytical tools;
- Providing automated support for modelers for activities performed during the *modeling life-cycle* phases in an integrated environmental assessment. These include: (i) problem identification; (ii) model specification in an algebraic statement; (iii) data collection; (iv) instance generation; (v) instance analysis; and (vi) model analysis [Marek, 2004];
- Support for documentation, presentation and dissemination of the most important environmental concerns, trends, emerging issues and condition;
- Allowing participatory process that ensures involvement of stakeholders and experts from every discipline that relates to environment and development issues [Parker et al., 2002].

Based on the above requirement, the development of general framework should adopt the important principle: (i) each individual models that needs to be linked should satisfy the generic interface demands; (ii) non-model specific functionality is generally available as reusable tools that may be linked to models; (iii) models may easily use the same basic data. The user may interact with any model through the common Graphical User Interface (GUI). From the interface, users can start simulations, review state variables, and visualize the results. The used models are chosen

based on the view points of the user needs, using data in database as input and the results as output of model is then stored in the database, which could be viewed and evaluated using tools and solvers by users based on their preferences. The solvers used to solve a problem might be a query processor or an equation solver for simulation and optimization.

5. IMPLEMENTATION ISSUES: STRUCTURED MODELING TECHNOLOGY

The main focus of development of this framework is to provide a platform for systems integration that adapted Structured Modeling framework. Structured Modeling Technology (SMT) was developed [Marek, 2004] to open client/server architecture, WWW technology, object-oriented paradigm and DBMS for extending the application focus of structured modeling towards the issues of sharing on modeling resources and multiple users. By taking an object-oriented view (C++) of Structured Modeling frameworks and its representation as a relational database or an object database, the implementation of model integration as a function of an object-relational DBMS (Oracle) becomes a feasible alternative and it can be accessed to using readily available Internet World Wide Web browser software.

Object-oriented programming. The applicability of object-oriented programming has been recognized by numerous researchers to model management and the associated benefits of models as objects, solvers bound to these models, and inheritance hierarchies. Object-oriented programming could provide techniques for managing enormous complexity and coupling data with the tasks that manipulate that data. Another advantage of this programming is its capability in achieving reuse of software component. Since all of features and functions of objects are encapsulated with the object themselves, systems can be structured in the terms of the relationships in a very problem oriented way, hiding the technicality of implementation in the objects' declarations. Objects become the flexible building blocks of modular systems that can be more easily adapted and redesigned, and reused as requirements change.

Over the last decade C++ has been widely used due to its great advantage for creating types of objects that closely correspond to the real-world objects being modeled. We use C++ because it fully supports object-oriented programming, including the three pillars of object-oriented development: encapsulation, inheritance, and

polymorphism as described above. Some description of the declaration of classes that supports encapsulation for SMT structures (using C++) can be seen in Makowski [2004].

Database Management System (DBMS). The DBMS is a vital tool needed for handling the complex data manipulation that earmarks large scale modeling. In this work, we use an object-relational DBMS, namely Oracle, as a way to meet the performance demand on the complex data.

The Internet and XML. The Internet has become the most significant new medium for communication between user and modeling resources that is essential to enhance the modeling process of an identified decision. The World Wide Web is used by the Internet to explore information. XML or eXtensible Markup Language is a widely used data format for structured and semi-structured text on the Web, for specifying the semantics of the model input and output [Rizzoli et al., 2001], linking databases to model inputs [Kokkonen, 2003] or documentations. Moreover, XML documents can be managed by DBMSs. An object-relational (object-based) mapping is used as the basis for software that transfers data between XML documents and relational databases. Replacing proprietary file formats with XML allows organizations to achieve much higher levels if reuse of semi-structured and unstructured data. For instance, information contained in an Excel spreadsheet is only accessible to the Excel program, or to program that uses Microsoft's COM APIs. The same information, stored in an XML document is accessible to any tool that can leverage the XML programming model.

6. CONCLUSIONS

Integrated Environmental Assessment requires modeling resources such as models, data sets, solvers, and tools that could support in producing accurate assessments of both the state of environment and the consequences of environmental policies. The lack of interoperability that permits integration of modeling resources remains a major constraint to accessing usable modeling resources. To do this effectively, they have to be integrated in a modeling environment to provide direct access to user community.

Recently, significant progress has been made towards the development and application of structured modeling technology on AIM/Trend. The most important aspects that could be offered

by structured modeling technology are: *flexibility*, *versatility*, and *accessibility*. The approach described in this paper coupled with the SMT provides: (i) a framework and system design for management of modeling resources which are needed by IEA; (ii) communication that could facilitate the involvement of multiple users.

7. ACKNOWLEDGEMENTS

The authors wish to thank Marek Makowski (IIASA) and M. Kainuma (NIES Japan) for their kind collaboration and providing us with all available data and access to AIM/Trend.

8. REFERENCES

- Brandmeyer, J.E., Karimi, H.A., Coupling methodologies for environmental models, *Environmental Modelling & Software* 15, 479-488, 2000.
- Brouwer, F.M., *Integrated Environmental Modeling: Design and Tools*, Jubels B.V., 229 pp., Amsterdam, 1986.
- Dolk, D.R., Kottelman, J.E., Model integration and a theory of models, *Decision Support System* 9, 51-63, 1993.
- Geoffrion, A.M., An introduction to structured modeling, *Management Science* 33(5), 547-588, 1987.
- Geoffrion, A.M., Integrated modeling systems, *Computer Science in Economics and Management* 2, 3-15, 1989.
- Greenberg, H.J., Mathematical programming models for environmental quality control, *Operations Research* 43 (4), 578-622, 1995.
- IPCC, *Special Report on Emissions Scenarios*, Cambridge University Press, Cambridge, 2000.
- Kainuma, M., Matsuoka, Y., Morita, T., *Climate Policy Assessment: Asia-Pacific Integrated Modeling*, Springer-Verlag, 402 pp., Tokyo, 2003.
- Kokkonen, T., Jolma, A., Koivusalo, H., Interfacing environmental simulation models and databases using XML, *Environmental Modeling and Software* 18, 463-471, 2003.
- Makowski, M., A structured modeling technology, *Feature Issues of EJOR on Advances in Modeling: Paradigms, Methods and Applications*, to be published in 2004.
- Parker, P., et al., Progress in integrated assessment and modeling, *Environmental Modeling & Software* 17, 209-217, 2002.

- Parson, E.A., Integrated assessment and environmental policy making in pursuit of usefulness, *Energy Policy* 23, 463-476, 1995.
- Rizzoli, A.E., Davis, J.R., Abel, D.J., Model and data integration and re-use in environmental decision support systems, *Decision Support Systems* 24, 127-144, 1998.
- Wierzbicki, A.P., Makowski, M., Wessels, J., *Model-based Decision Support Methodology with Environmental Applications*, Kluwer Academic Publishers, 475 pp., Dordrecht, 2000.
- Bhatt, N., and C.A. Cole, Impact of conservation on rates and operating costs, *Journal of et al. Water Resources, American Society of Civil Engineering*, 11(2), 192-206, 1985.