

# An Integrated Modelling Approach for Assessing Water Policy Rules and Land Use Change Options

Juliet Gilmour<sup>a</sup> R.Letcher<sup>b</sup>

<sup>a</sup> Centre for Resource and Environmental Studies, Australian National University

<sup>b</sup> Integrated Catchment Management and Assessment Centre, Australian National University  
ACT, 0200. Australia. Email: [jgilmour@cres.anu.edu.au](mailto:jgilmour@cres.anu.edu.au)

**Abstract:** The primary aim of the study has been to develop a modelling framework to quantitatively assess the impact of water allocation rules upon economic and biophysical environments (primarily hydrological) at the catchment scale. This paper identifies development of the modelling approach to answer allocation questions by examining hydrological, land and agricultural production systems. The conceptual framework underpinning the modelling approach identifies the major aspects of integration between hydrological and production systems. The production model is integrated at various points within the hydrological cycle including rainfall, streamflow and runoff components. The outcome of the approach allows water to be moved around the catchment to quantify impacts and understand trade-offs as a result of policy imposition and land use change. The results indicate the land use change for salinity management has the potential to impact upon intensive activities within the catchment such as viticulture.

**Keywords:** Integrated modelling, agriculture, catchment management, land use change, hydrology

## 1. INTRODUCTION

### 1.1 Water Policy Setting

Water policy issues introduced by the NSW State Government are designed to balance environmental and socio-economic needs at the catchment scale. The potential for a set of policies to negate existing environmental efforts is one reason why interpolicy impacts are required to be identified. In addition, a set of physical impacts upon the catchment can be expected with any policy option implemented. Each option has a set of onsite and offsite consequences. The preferred policy option requires an understanding of trade-offs between land and water systems as well as potential impacts upon other policy options to identify what options are most suitable for whole catchment systems.

### 1.2 The Modelling Approach

An integrated modelling approach is designed and applied at the catchment scale in order to:

- Qualitatively and quantitatively identify interpolicy impacts
- Quantitatively identify socio-economic and environmental impacts and associated trade-offs in time and space as a result of

introducing several land and water policy options

A conceptual framework underpinning the approach would identify all relevant aspects of integration between economic, environmental and hydrological systems. The hydrological modelling component of this study required streamflow in ungauged catchments using a regionalisation approach. The development of this water balance for the catchments as well as model calibration is given in Croke *et al.* (2001), Croke (2001), Croke and Jakeman (2001), Gilmour and Croke (2001) and Gilmour (2000). The development of the agricultural production system modelling component is found in Gilmour and Watson (2001).

### 1.3 Study Catchment

The Yass catchment is an unregulated river system located in the Upper Murrumbidgee. The catchment suffers from water quantity problems as a result of the over extraction of water, and water quality problems as a result of dryland salinisation (DLWC 1999).

Three policy options are to be implemented in the catchment in an effort to reduce each of these environmental problems (DLWC,1999b). Each of the following policy options was selected to be

incorporated in the model development. They were;

1. The Farm Dams policy;
2. Volumetric Conversions, and
3. Salinity Management Strategy by forestry plantation.

The Farm Dams policy restricts the capture of runoff from farm dam development. The Volumetric policy is designed to restrict in-stream extractions while the third policy is aimed at plantation development to reduce rising water tables in the catchment.

## 2. CONCEPTUAL FRAMEWORK

The conceptual framework is the foundation for model development. Model integration is between the agricultural production system and the hydrological system within Yass catchment. The approach uses a modelling hierarchy to conceptualise the catchment land, water and production system. Model development uses the hierarchy to provide a consistent and generic approach to building and integrating models to represent the catchment system.

### 2.1 Modelling Hierarchy

In order to identify the important points of integration between systems, each land use system in the catchment was characterised as a set of activities. The activities and their relation to the hydrological systems are given in Table 1. In all, six activities were identified in the catchment.

**Table 1:** Catchment Land use activities and their point of integration with the hydrological cycle

Activity	Point of Integration with hydrology
Forestry on low yielding soils	<ul style="list-style-type: none"> <li>• Runoff capture (overland flow)</li> </ul>
Forestry on high yielding soils	<ul style="list-style-type: none"> <li>• Runoff capture (overland flow)</li> </ul>
Grazing	<ul style="list-style-type: none"> <li>• Rainfall</li> </ul>
Viticulture	<ul style="list-style-type: none"> <li>• Runoff capture ( farm dam capture)</li> </ul>
Lucerne Irrigation	<ul style="list-style-type: none"> <li>• Streamflow capture (extractive use)</li> </ul>
Rotational cropping	<ul style="list-style-type: none"> <li>• Streamflow capture (extractive use)</li> </ul>

The second level in the modelling hierarchy is the Land Management Unit (LMU). The purpose of defining LMUs was to identify economically homogenous areas that react in a defined way to system changes (i.e policy changes).

Identification of each LMU proceeded by profiling economic production systems (activities) specific to the catchment system. Each activity was classified as either;

1. Dryland
2. Dryland Supplementary
3. Irrigation

The classification is dependent upon the way in which each activity uses water in the catchment and hence how the problem is modelled. Dryland supplementary LMUs consist of those activities that use farm dams as part of the production system while irrigation LMUs are those activities that extract water directly from the stream. A spatial profile of the catchment revealed that several types of LMUs exist in a single spatial area. Where this is the case, a modelling node was formed. A node is the third level in the conceptual framework. A node defines the point at which systems response is modelled and indicators calculated. The relationship between nodes and LMUs is shown in Figure 2.

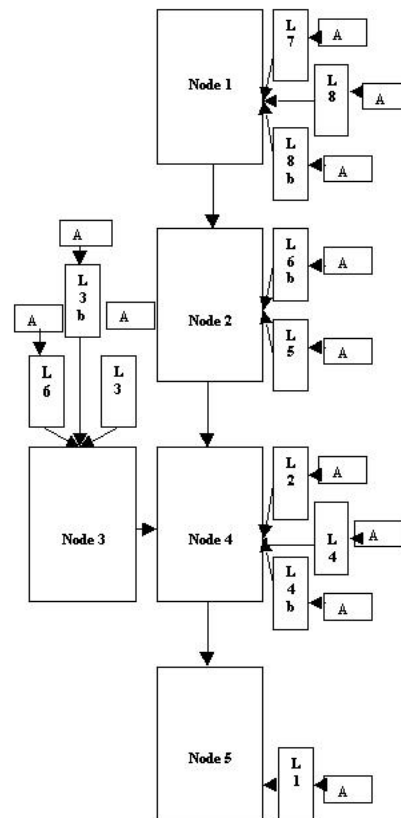

**Figure 2:** Relationship between Nodes, LMU's and activities (A= Activities, L= Land Management Units)

The model conceptualisation in relation to the spatial area of the catchment is illustrated by Figure 3.

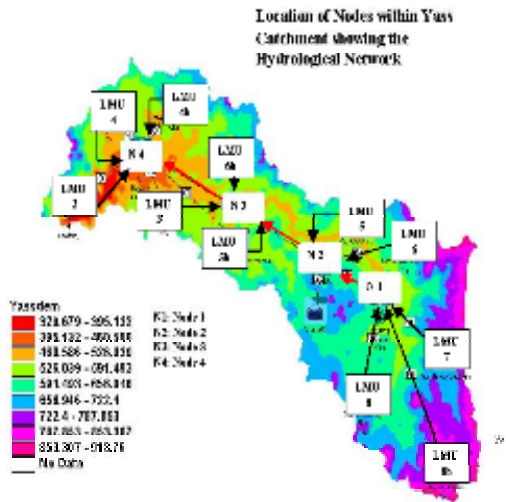
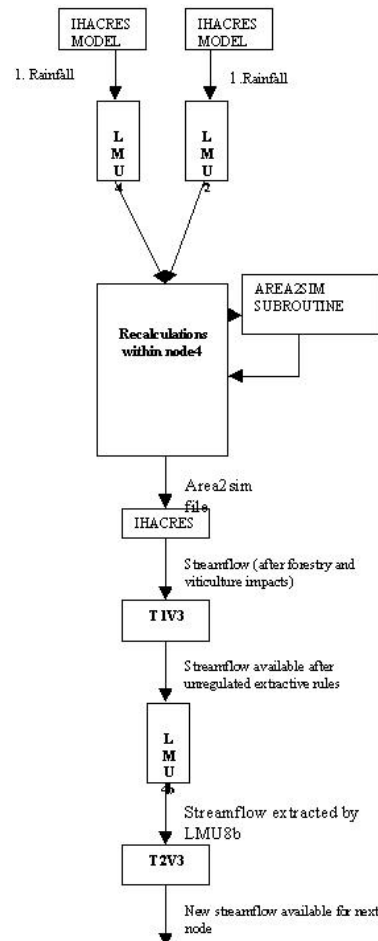

**Figure 2:** Relationship between catchment spatial characteristics and the model conceptualisation

## 2.2 Model Integration

The final step in developing the conceptual framework was to define how the production models and hydrological models were to be integrated within the activities, LMUs and nodes. Figure 3 illustrates model integration for a single node system. The rainfall runoff model calculates effective rainfall remaining (after evapotranspiration). This is used as model input into the dryland activity yields for grazing and forestry respectively. The second step in model integration involves adjusting the total level of runoff as a result of forest interception for the dryland LMU and farm dam capture for the supplementary activity, viticulture. The rainfall runoff model utilises the forested area, farm dam drainage area and the total farm dam volume to recalculate total runoff to the stream system after making an adjustment to evapotranspiration in the rainfall runoff model. The adjustment to streamflow is then made by a second pass through the rainfall-runoff model to give the total available streamflow for the third LMU type. irrigation activities. LMUs containing extractive activities are given an allowable streamflow allocation (given by a subroutine called T1v3). The streamflow available for downstream land uses is then recalculated (given by a subroutine called T2V3) and then passed to the next node downstream. Area2sim is a subroutine that takes output from the agricultural production model and places it into a format that the hydrological model can read as an input to calculate streamflow.

The temporal and spatial scale of the models were also a consideration when integrating the model. The hydrology model was a daily rainfall runoff model calibrated at the daily time step. However the agricultural production system is a seasonal time step. The output from the hydrology model is required to be aggregated to the seasonal time step of the agricultural production model.



**Figure 3:** Model Integration. Example from Node 4 where T2V3, T1V3 and Area2sim are model subroutines.

## 2.3 Modelling Objectives

The major objective initially selected for the integrated modelling procedure was to optimise income derived from agricultural production activities subject to a series of constraints. A linear programming formulation was utilised to carry out this objective. The constraints were of three main types: a water constraint; a land area constraint and other biophysical constraints such as slope and aspect constraints in the case of the viticulture production systems for example. Each

constraint was subject to change in the model according to the policy option imposed. For example, a salinity management policy changed the land area constraint while a volumetric policy option changed the water constraint. In varying policy options and hence the model constraints, the change in income derived from each agricultural production activity was obtained.

### 3. MODEL SCENARIOS

The spatial nature of the modelling approach allows impacts between agricultural production systems and the hydrology of the catchment to be modelled and associated trade-offs to be considered. The scenarios run for each policy option may be assessed in the context of either land use change or the imposition of new water allocation rules. The base case model run was determined by obtaining data from time series data such as rainfall and temperature as well as spatial data from a Geographic Information System. Spatial information included area currently planted to agricultural activities. The first set of scenarios examines the impact upon the catchment system as a result of allowing expansion of the viticulture industry. The second set of potential scenarios that can be run is the impact upon agricultural production systems as a result of imposing water allocation policies such as restriction on the percentage of runoff captured or the imposition of new volumetric rules. The options for the second set of scenarios are indicated by Table 2. The land use change scenarios allow variation in the demand for water in the catchment. The second set of scenarios allows for variation in the supply of water within the catchment.

**Table 2:** Scenarios to analyse impacts as a result of the changes in water supply.

LMU 1 (Dryland)	LMU 2 (Supplementary Irrigation)	LMU 3 (Irrigation)
<b>Salinity Management</b>	<b>Farm Dams Policy</b>	<b>Volumetric Conversions</b>
1.Plantation of softwood 20%	1.10% runoff rule	1.Multiple extraction limits trials
2.Plantation Of 50%	2.5% runoff rule	
3.Plantation of 70% of catchment	3.No % runoff restriction	

A base case model was constructed to ensure the model could represent the current catchment system at the policy scale of interest. Scenario runs were then compared with the base case

model to identify the magnitude of impacts and trade-offs upon the catchment systems given the imposition of the three policy options.

Model output from each scenario run includes streamflow at each node, activity area and economic return at the LMU and node level. These outputs allow a comparison of water use, land area and economic return to be identified for each activity under scenario options. Changes in the model output allow trade-off analysis to be conducted.

### 4. MODEL RESULTS

The model was simulated over a 20 year time horizon. The base case model was run to ensure the model representation of the catchment system was adequate for the scale and purpose of the modelling approach. Figure 4 indicates the result generated by running the base case scenario. The model presently overestimates forestry activities in the catchment by approximately 20%.

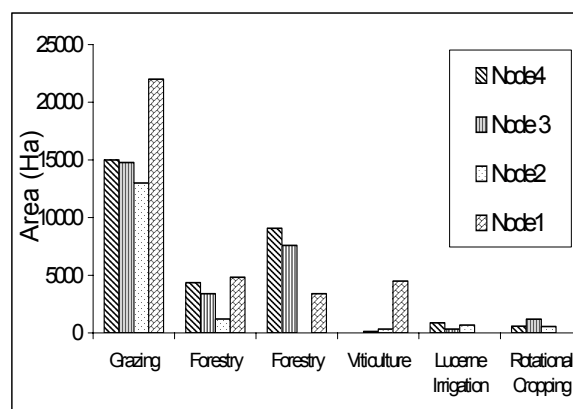

**Figure 4:** Results from the base case model. Activity area in hectares

#### 4.1 Example: Farm Dams Policy

A scenario was run to analyse the impact upon land use activities as a result of imposing a limit upon the allowable capture of runoff for supplementary irrigation activities. The policy is expected to have the greatest impact upon viticulture activities (owing to its reliance upon farm dams for vineyard establishment). The results indicated are for viticulture only. Figure 5 indicates the change in area planted to viticulture before the imposition of the farm dam policy restricting capture to 10% of total runoff and after policy imposition at each node.

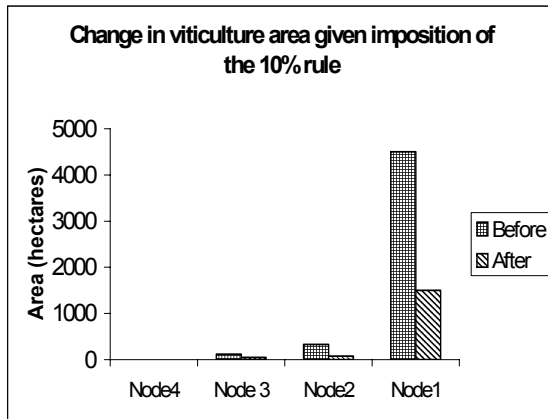
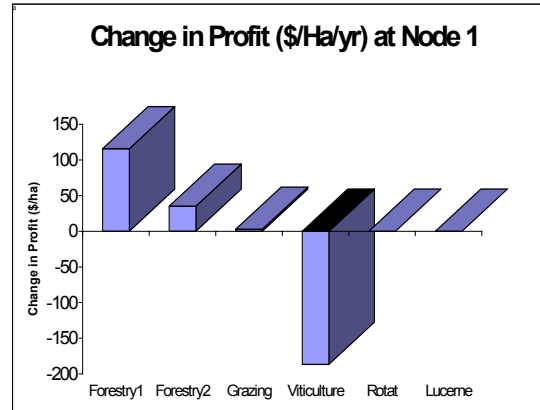

**Figure 5:** Change in viticulture area as a result of imposing the 10% Farm Dams Policy Rule.

As indicated by Figure 5, area planted to viticulture is reduced by more than 50% in Node 1. Node 4 is not considered economically viable for a viticulture enterprise. Hence zero area is planted.

#### 4.2 Example: Salinity Management Strategy

A second scenario was run to examine the economic impact upon activities at Node 1 given the introduction of forestry plantation across 20% of the catchment. As Figure 6 indicates, the viticulture activity has a loss of \$186 per year per hectare. This is due to the reduction in catchment area to establish the "valued added" activity and the loss in water available in the catchment for supplementary irrigation as a result of the reduction in runoff given the plantation of forests. The profit obtained from forestry obviously increases owing to its imposition upon the catchment while the economic return from lucerne and rotational cropping activities remain unchanged given that forestry activities do not occur within land suitable for irrigation. Interestingly, grazing economic return increases as land is taken out of production from viticulture and returned to grazing (when compared to the base case model run).



**Figure 6:** Change in profit as a result of introducing salinity management strategies

## 5. CONCLUSIONS AND RECOMMENDATIONS

The modelling approach, although applied specifically here for Yass catchment, is generic enough in its development to be applied to other unregulated catchments in the Upper Murrumbidgee indicated in Figure 1. The approach could be utilised for other upper catchment systems that are undergoing land use change toward more value added agricultural industries. The analysis also assists the current lack of information as to how new water reforms will impact upon unregulated catchments. In this way, the model could be extended to provide decision support to aid the choice of water policy. In particular, the Farm Dams Policy, Salinity Management Strategies and In-stream Extraction rules are able to be examined with the modelling approach.

Future work will involve analysing scenarios for each of the three policy options in addition to investigating the impacts as a result of land use changes in the catchment. This will involve investigating spatial trade-offs between the hydrology and the agricultural production system within Yass catchment. Scenario analysis will focus upon spatial trade-offs between policy options, the availability of water for environmental purposes and the economic viability of catchment activities.

## 6. ACKNOWLEDGEMENTS

The author would like to acknowledge Professor Tony Jakeman and Dr Barry Croke for their guidance in development of the hydrological system. Thanks to Rebecca Letcher and Bill Watson for their guidance and input into the conceptual framework and production systems

model formulation. Thank you to Rebecca and Jess Spate for help with coding the model in MATLAB.

## 7. REFERENCES

- Croke, B.F.W., A technique for deriving the Unit Hydrograph from streamflow data, in preparation, 2001.
- Croke, B.F.W. and A.J. Jakeman, Revised IHACRES CMD model, in preparation, 2001.
- Croke, B.F.W., Gilmour, J.K and Newham,L. A comparison of rainfall estimation techniques. In Proceedings of The Third Annual Healthy Streams Conference. Brisbane. 2001.
- Gilmour, J.K and Croke, B.F.W. Prediction of Streamflow to Assess Trade-offs from Water Policy Rules and Land Use Intensification. In, *Proceedings for the Modelling and Simulation Society*. Canberra, 2001
- Gilmour.J.K. 'An approach for predicting streamflow within the Yass catchment'. In *"Proceedings of the International Symposium on Hydrology*. Institute of Engineers, Perth. 2000.
- Gilmour.J.K and W. Watson. An Integrated Approach for Assessing Water Allocation Rules. In, Proceedings for the Australian Agricultural and Resource Economics Society, Adelaide, 2001
- DLWC (1999a) " *A proposal for updated and consolidated water management legislation for New South Wales*". Department of Land and Water Conservation, Sydney.
- DLWC (1999b) "*Dryland Salinity in the Yass river catchment: Processes and Management*". Department of Land and Water Conservation. Yass