

A Simulation System for Waste Management – From System Dynamics Modelling to Decision Support

P.A. Wäger and L.M. Hilty

*Swiss Federal Laboratories for Materials Testing and Research (EMPA),
Lerchenfeldstrasse 5, CH-9014 St. Gallen (patrick.waeger@empa.ch)*

Abstract: With ongoing differentiation of society and an increasing demand to consider sustainability principles, instruments to support the assessment, design and control of complex socio-technical systems will gain importance. In this context, computer-based numerical models may play an essential role. We present a system dynamics based simulation system for plastics waste management and discuss the practical experiences made with this system. The simulation system – called EcoSolver IP-SSK - combines the advantages of a system dynamics approach with expertise from the field of Life Cycle Assessment (LCA). EcoSolver IP-SSK has been developed in cooperation with key players of the waste management system and supports the assessment of the flow of materials, energy and costs in regional waste management with regard to their ecological and economic impacts. The software system consists of an *input module* for the definition of waste streams and process parameters according to the scenario defined; a *simulation module*, which includes the core model representing relevant processes of transportation, collection, sorting and treatment as well as sub-models for the ecological and economic assessment; and finally *the output module*, which visualises the simulation results on different levels of the disposal system (single processes, disposal routes, disposal system). Strengths and weaknesses of EcoSolver IP-SSK observed in practice show that there is a general need for improvement concerning the clarification of model structure, the assessment of parametric uncertainty and sensitivity, as well as the support for systematic validation and robustness tests. Regarding its intended application as a decision support system (DSS), modifications and extensions of EcoSolver IP-SSK will focus on its ability to support explorative learning about socio-technical systems.

Keywords: Decision Support System; Material Flow; Modelling; Simulation; Sustainability

1. INTRODUCTION

1.1 Increasing Complexity and Awareness of Human Action

Due to ongoing differentiation processes, which manifest in an increasing variety of specialised key players and technical systems, society gets more and more interrelated and complex. Typical characteristics of complex socio-technical systems are [Sterman, 2000; Willke, 1996]:

- their dynamism, following from strong interactions between actors, from feedbacks, non-linearities, path-dependencies, trade-offs and the distance between cause and effect in time and space.
- a great number of possible actions, from which the most adequate has to be chosen in order to ensure the survival of the system;
- the emergence of conflicts about the question, which of the possible actions are to be

preferred under the conditions of limited resources;

- hardly foreseeable consequences of decisions.

At the same time, the awareness of the consequences of human action regarding their number and type as well as their extension in space and time increases. This is especially true with regard to the sustainable development discourse. Sustainable development involves the simultaneous pursuit of economic prosperity, environmental quality and social equity.

1.2 Complexity Management Supported by Modelling and Simulation

A prerequisite for the management of complex socio-technical systems with regard to principles of sustainable development is the assessment of multiple alternatives of action, which in turn

requires a (re-)integration of distributed knowledge and experiences.

An obvious approach to such an assessment is the application of modelling and simulation techniques. This approach becomes the more attractive, the more the processing speed of computers increases and modelling and simulation tools become powerful, cost-efficient and user-adequate.

In the field of planning and decision making, modelling and simulation techniques can particularly be applied to

- study the (dynamic) behaviour of the socio-technical system of concern (e.g. the waste management system) in different scenarios;
- check the robustness of a policy against possible changes in the scenarios;
- simulate and assess the effects of different strategies with regard to basic principles of sustainable development [Hilty et al. 2001].

1.3 Integration with Traditional Planning and Decision Making Procedures

The integration of modelling and simulation techniques into traditional planning and decision making procedures (e.g. in regional waste management), still seems to be in its infancy: scepticism regarding the practical relevance and

trustworthiness of simulation models is usual.

We present an example of a simulation system that has been applied in the field of waste management and discuss it with regard to general requirements for decision support systems [Risbey et al., 2001]). Such a system can be viewed as the macro level complement of the corporate information systems used for production and recycling planning and control on the micro level [Hilty et al. 1997].

2. A SIMULATION SYSTEM FOR PLASTICS WASTE MANAGEMENT

2.1 Initial Situation

As a consequence of the increasing amounts of municipal solid waste expected and observed since 1999, additional Municipal Solid Waste Incineration (MSWI) capacities are planned to be installed in Switzerland.

These intentions have led to controversial discussions, in which plastics waste plays an important role: Due to its amount (which was estimated to amount to 570'000 tons in 1999 [SAEFL, 1999]), its heating value (which exceeds the heating value of typical MSWI waste by a factor of approximately 3) and its potential for recycling and thermal recovery in cement kilns, an additional diversion of plastics waste from MSWI plants into cement kilns and materials recycling

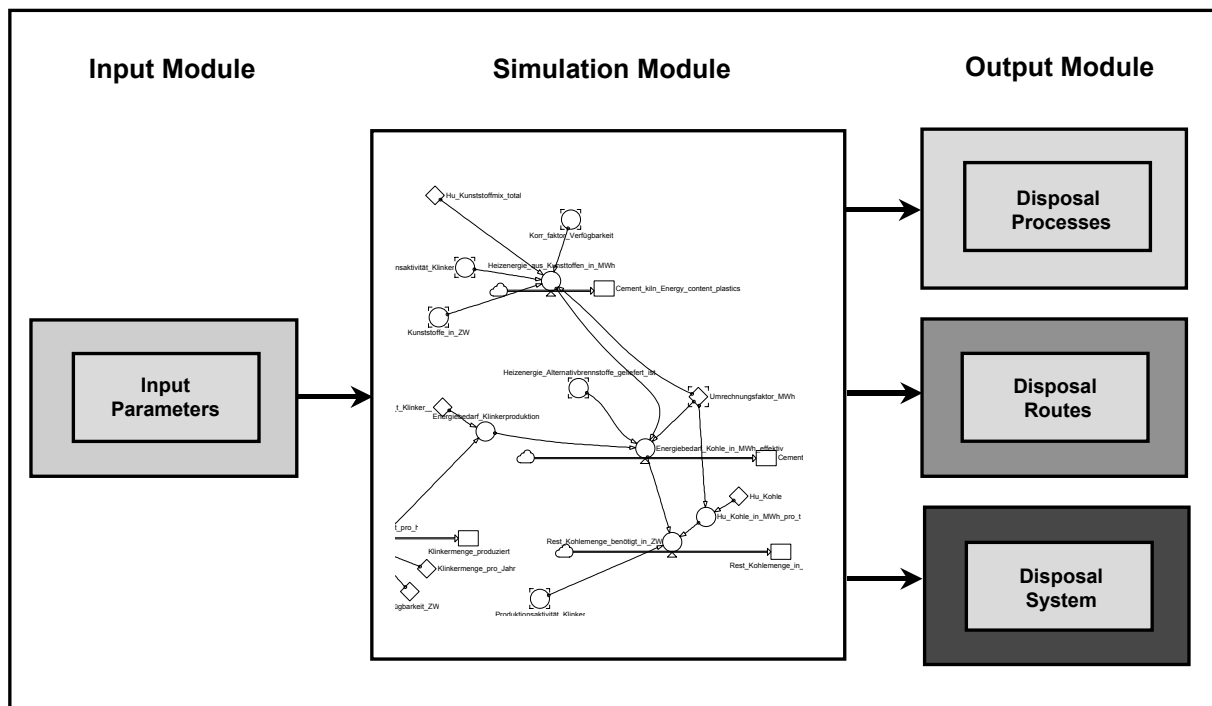

Figure 1: General structure of EcoSolver IP-SSK

facilities could allow to avoid at least part of the planned investments into additional MSWI-capacities. At present, more than 80% of the plastics waste arising in Switzerland is incinerated in MSWI plants.

2.2 The EcoSolver IP-SSK

To answer the question whether an additional diversion of plastics waste would be a suitable alternative to extending MSWI-capacities, EMPA was commissioned to develop a simulation system in cooperation with Rytex Inc. Münsingen and relevant Swiss waste management actors.

The system – called EcoSolver IP-SSK – has been implemented using the system dynamics simulation software Powersim[®] Constructor [Powersim Corporation 1996]. Based on the results of the project ‘Dynamics of Waste Treatment’ [Widmer et al. 1998], it has been conceived as a system which allows to simulate the ecological and economic effects of possible future developments (scenarios) in regional plastics waste management for time periods up to 15 years.

EcoSolver IP-SSK consists of an input module, a simulation module and an output module (see figure 1).

a) Input Module

The input module allows the user to set input parameters - e.g. the expected development of the waste streams in the disposal system under study, the amounts of thermally recovered or recycled plastics waste as well as the transportation distances – according to a defined scenario (see figure 2).

b) Simulation Module

The simulation module includes the core model and additional sub-models for an ecological and economic assessment. In *the core model*, the transportation, collection, sorting and treatment processes related to the disposal routes considered (incineration in MSWI plants, thermal recovery in cement kilns and mechanical recycling) are represented. As a database, indicators for processes and systems typically found in Switzerland have been used (specific energy consumption, specific emissions of CO₂, NO_x, Cd, Hg, COD, etc.). Central element of the core model is the incineration process in MSWI plants, which has been modelled in detail.

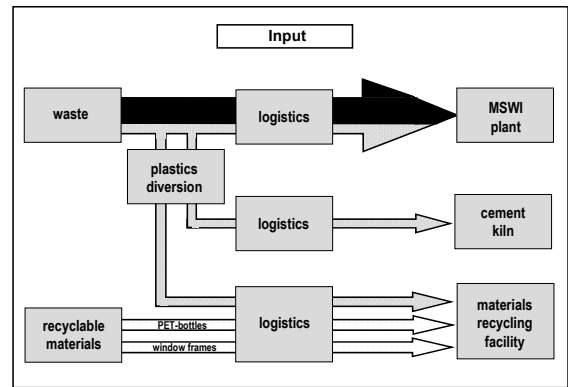

Figure 2: Structure of the Input Module of EcoSolver IP-SSK

The *ecological assessment* of the disposal system is based on the problem-oriented CML method employed in Life-Cycle Impact Assessment (LCIA), and the ‘basket of products’ principle, which allows a fair comparison of scenarios with different outputs [Fleischer 1994; Förster and Ishikawa 1999; SAEFL 1998a]. In addition to the impact assessment categories (abiotic resource depletion, global warming, ozone layer depletion, etc.), environmental indicators are calculated in order to consider important environmental aspects which are not addressed by the CML method (amount of waste materials, heavy metal distribution into different compartments, etc.).

For calculating the inventories and the impact assessment categories, published (average) data have been used [SAEFL 1998a, 1998b].

The *economic assessment* is based on process-specific economic indicators. For the time being, it is limited to single processes and disposal routes.

c) Output Module

The output module shows the results of a simulation run on three different levels:

- processes (e.g. the incineration process in an MSWI plant, see figure 3);
- disposal routes (i.e. the sum of the disposal processes for each disposal option);
- entire disposal system under study.

2.3 SIMULATING WITH ECOSOLVER IP-SSK

EcoSolver IP-SSK allows to simulate the diversion of plastics waste from an MSWI plant into thermal recovery and recycling facilities. In order to evaluate the simulation results, the output of a scenario has to be compared to the output of a reference scenario.

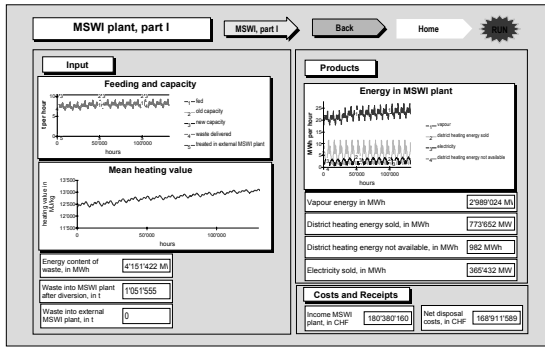

Figure 3: Simulation output of EcoSolver IP-SSK

As MSWI plants differ from each other in technology and operating conditions, simulation results are specific for the type of MSWI plant, i.e. the geographic region considered.

3. EXPERIENCES FROM SYSTEM DEVELOPMENT AND APPLICATION

3.1 Simulation System Development

The simulation system has been developed in close cooperation with Swiss waste management actors, i.a. the Swiss Agency for the Environment, Forests and Landscape (SAEFL) and operators of MSWI plants, cement kilns and recycling plants, on the occasion of several workshops.

The goal of the modelling process was to answer the key question: What will happen, if up to 200'000 tons of plastics waste per year are taken out of the waste stream, which is incinerated in Swiss MSWI plants, and fed into thermal recovery or mechanical recycling instead?

The principal experience we made during the development of EcoSolver IP-SSK is that the integration of key players in a model building process facilitates the discussion between conflicting parties and, to some degree, brings diverging interests closer together.

However, it was not possible to motivate all the key players involved to regularly participate in the process. The participants' lack of knowledge in system dynamics modelling as well as the growing complexity of the model developed regarding its structure and parameters made it additionally difficult to keep them on the same information level and to avoid a bias in the outcome of the process. In particular, many small but important decisions had to be taken by the modellers without the possibility to consult the relevant key players.

A consequence of the opacity of the model in the key players' view was that they attached exceptionally high significance to the user interface when

assessing the quality of the model. The importance of model transparency is already known from earlier empirical studies [Häuslein et al., 1988].

3.2 Application

EcoSolver IP-SSK has been applied to simulate thermal recovery and recycling options of plastics waste in a model region of 207'000 inhabitants around a MSWI plant with changing capacities over a time period of 15 years [Wäger and Gilgen, 2000]. The corresponding scenarios were defined in cooperation with the same key players involved in the model building process and based, among other things, on following assumptions:

- in the year 10 of the simulation period the MSWI plant is renewed;
- plastics waste thermally recovered in the cement kiln complies with the standards of the Swiss Agency for the Environment, Forests and Landscape [SAEFL, 1998c];
- there is a market for secondary plastics material.

Like model building, scenario definition did not equally involve all the key players.

The results of the simulation experiments carried out by the modellers were presented to the key players on the occasion of the workshops held and - where necessary and possible - discussed on additional bilateral meetings. They indicate that a diversion of industrial plastics waste from the waste stream into MSWI plants has ecological as well economic advantages under the conditions specified. Hence it seems advisable to develop and investigate concrete strategies for plastics waste diversion.

Due to time limitations in the project, simulation results and action recommendations could be discussed only briefly. During the discussions it turned out to be difficult to communicate all the implicit assumptions and parameter settings. The plausibility of the simulation results could more or less easily be checked for indicators, which had their concrete counterpart in everyday professional life of the key players (e.g. electricity consumption in a recycling process). However, the access to aggregated values related to ecological and economic assessment seemed to be more difficult.

3.3 Communication of Results

To stimulate a discussion of (intermediary) results of the study, the scientific community, the general public and the relevant decision makers have been

continuously informed about the progress of the project. A decisive step towards implementation of action recommendations has been done by formulating a petition to the address of the Swiss Government [UREK, 2001].

4. ECOSOLVER IP-SSK - A DECISION SUPPORT SYSTEM?

4.1 Strengths and Weaknesses of EcoSolver IP-SSK

The development and application of EcoSolver IP-SSK was determined by practical requirements and restrictions. In view of future applications and possible extensions of the software, a critical investigation is required. Below, strengths and weaknesses of EcoSolver IP-SSK observed in practice are addressed.

a) Strengths of EcoSolver IP-SSK

- EcoSolver IP-SSK addresses a well-defined real-world problem in the field of waste management;
- EcoSolver IP-SSK allows to simulate scenarios, extending the System Dynamics approach by elements of Life Cycle Assessment (LCA);
- EcoSolver IP-SSK calculates simulation results for different aggregation levels (the disposal processes, the disposal routes and the disposal system);
- EcoSolver IP-SSK integrates ecological and economic assessment approaches;
- EcoSolver IP-SSK at least partially reflects the knowledge of relevant key players, who participated in the model building process.

b) Weaknesses of EcoSolver IP-SSK

- The complex model structure as well as the great number of parameters to be set makes the identification and communication of underlying concepts and assumptions difficult.
- The modelling language is unfamiliar to typical key players.
- The systematic assessment of parametric uncertainty and sensitivity is not supported.
- The systematic validation of the model is not supported.
- EcoSolver IP-SSK is not yet suitable to be applied interactively in participatory decision making processes, because complex simulation experiments are not performed automatically.

4.2 Need for Improvement

From the above discussion of the strengths and weaknesses of EcoSolver IP-SSK, we deduce that

there is some need for improvement regarding its general characteristics as a simulation system on the one hand and its specific characteristics as a decision support tool on the other hand.

The greatest improvement potential for EcoSolver IP-SSK *as a simulation system* lies in increasing transparency by clarification of model structure and user-interface, e.g. by a more strict modularisation. This will allow to better communicate and discuss the underlying concepts and assumptions. In addition, more importance should be attached to the assessment of parametric uncertainty and sensitivity as well as to validation and robustness tests.

The identification of the improvement potential regarding an application of EcoSolver IP-SSK *as a decision support system (DSS)* first requires a more precise definition of its intended role in decision support processes. One (theoretical) possibility would be to regard EcoSolver IP-SSK as a "general problem solver" for waste management issues, allowing decision makers to *delegate their responsibility* to the tool. Another (more realistic) role for EcoSolver IP-SSK would be that of an *explorative learning tool* for waste management policies. This would allow the participants of decision making processes to better share perspectives and insights, which again would facilitate consensus-oriented solutions.

In this context, the main improvement potential lies in an enhanced user-orientation of the system. This requires, among other things, an intuitively accessible, user-specific interface and a better transparency of model assumptions.

Furthermore, a Web-based user interface would enhance the system's potential to support participatory group learning [Hare et al., 2001].

5. CONCLUSION AND OUTLOOK

With EcoSolver IP-SSK, a system dynamics based simulation system for plastics waste management issues has successfully been developed and applied. Strengths and weaknesses of EcoSolver IP-SSK observed in practice show that there is a general need for improvement concerning the clarification of model structure, the assessment of parametric uncertainty and sensitivity, as well as the support for systematic validation and robustness tests. Regarding its application as a decision support system, future modifications and extensions of EcoSolver IP-SSK will focus on its ability to support explorative learning about socio-technical systems.

In order to include the role and behaviour of key players in socio-technical systems into the model, we are working on an integration of multi-agent modelling approaches into the framework of EcoSolver IP-SSK.

6. ACKNOWLEDGEMENTS

The authors wish to thank Rytec Inc. Münsingen and the Swiss waste management actors involved in model development and application. The Swiss National Science Foundation, the Swiss Agency for the Environment, Forests and Landscape (SAEFL), the Association of Plastics Manufacturers in Europe (APME), the Swiss Plastics Association (KVS), the Swiss PVC Association (PVCH), PET-Recycling Switzerland (PRS), the working group 'New Fuels in Cement Industry' of the Swiss Cement Kilns, Poly Recycling Inc. and the Swiss Foundation for the Reintegration of Plastic Materials (SSK) have gratefully supported the project.

7. REFERENCES

- Fleischer G., Methodik des Vergleichs von Verwertungs-/Entsorgungswegen im Rahmen der Ökobilanz. *AbfallwirtschaftsJournal* 6(10), 697-701, 1994.
- Förster R., and M. Ishikawa, The Methodologies for Impact Assessment of Plastics Waste Management Options – How to handle Economic and Ecological Impacts? In: Barrag A. and Edelmann X. (eds.) R'99 Congress Proceedings, Vol. I, 220-225, Geneva, 1999.
- Hare M., N. Gilbert, D. Medugno, T. Asakawa, J. Heeb and C. Pahl-Wostl, The Development of an Internet Forum for Long-Term Participatory Group Learning About Problems and Solutions to Sustainable Urban Water Supply Management, In: Hilty L.M. and Gilgen P.W. (eds.) Sustainability in the Information Society, 15th International Symposium Informatics for Environmental Protection, Zürich, October 10-12, Metropolis Verlag, 743-750, Marburg, 2001.
- Häuslein A., and L.M. Hilty, Zur Transparenz von Simulationsmodellen. In: Valk, R. (Hrsg.), GI – 18. Jahrestagung – Vernetzte und komplexe Informatiksysteme, Springer, 279-293, Hamburg, Berlin, Heidelberg, New York, Tokio, 1988.
- Hilty L. M., R. Meyer and T.F. Ruddy, A General Modelling and Simulation System for Sustainability Impact Assessment in the Field of Traffic and Logistics. In: Rautenstrauch, C. (ed.): Environmental Information Systems in Industry and Public Administration. Idea Group Publishing, 167-185, Hershey (PA), 2001.
- Hilty L. M., and C. Rautenstrauch, Environmental Information Systems for Production and Recycling. In: Swayne D.; Denzer R.; Schimak G. (Eds.), Second International Symposium on Environmental Software Systems (ISESS), Whistler (Canada), Chapman & Hall, 21-29, New York, 1997.
- Powersim Corporation, Powersim 2.5. Reference Manual. Powersim press, Powersim Corporation Herndon VA / USA, Powersim AS Isdalstø, Norway, 1996.
- Risbey J., J. van der Sluijs, J. Ravetz and P. Janssen, A Checklist for Quality Assistance in Environmental Modelling. Dept. of Science, Technology and Society, Utrecht University. NWS-E-2001-11. July 2001. <http://www.nusap.net/downloads/reports/E2001-11.PDF>.
- SAEFL, Assessment of Ecoinventories. Environmental Series No. 300. Volumes I and II. Swiss Agency for the Environment, Forests and Landscape, Bern, 1998a.
- SAEFL, Life Cycle Inventories for Packagings. Environmental Series No. 250. Volumes I and II. Swiss Agency for the Environment, Forests and Landscape, Bern, 1998b.
- SAEFL, Entsorgung von Abfällen in Zementwerken. Richtlinie. Vollzug Umwelt. Bundesamt für Umwelt, Wald und Landschaft, Bern, 1998c.
- SAEFL, Kunststoffabfall im Haushalt separat sammeln? BUWAL Bulletin 1/99. <http://www.buwal.ch/bulletin/1999/d1a17s01.htm>, 1999.
- Sterman J.D., *Business Dynamics. Systems Thinking and Modeling for a Complex World*. McGraw-Hill, 982 pp., Boston, 2000.
- UREK-N, Bessere Verwertung von Kunststoffabfällen. Postulat der nationalrätlichen Kommission 'Umwelt, Raumplanung, Energie' (UREK-N) vom 22. Oktober z.H. der Eidgenössischen Räte, 2001.
- Wäger P., and P.W. Gilgen, Auswirkungen der thermischen und stofflichen Verwertung von Kunststoffabfällen auf die schweizerische Abfallwirtschaft. EMPA-Report Nr. 249, December 2000.
- Widmer H., P. Steiner, S. Textor and M. Walser, Betriebsoptimierung und Investitionsplanung in der Abfallbehandlung. *Müll und Abfall* 12, 753-761, 1998.
- Willke H., *Systemtheorie I: Grundlagen*. Lucius & Lucius Verlagsgesellschaft, 301 pp., Stuttgart, 1996.