

# Feeding Elk in Greater Yellowstone: A Case Study in Ex-ante Group Decision Support

Lynne Caughlan<sup>a</sup> and Dana Hoag<sup>b</sup>

<sup>a</sup> *Midcontinent Ecological Science Center, U.S. Geological Survey, Fort Collins, Colorado  
(lynne\_caughlan@usgs.gov)*

<sup>b</sup> *Department of Agricultural and Natural Resource Economics, Colorado State University,  
Fort Collins Colorado*

**Abstract:** Natural resource management decisions are complicated by multiple property rights, management objectives, and stakeholders with varying degrees of influence over the decision making process. Managers must consider all opinions when they develop management policies. Often this type of information is not understood until **after** a decision has been made, which can result in wasted time and effort. We developed an institutional framework to predict stakeholders' influence in the resource management decision-making process before the stakeholder meetings actually occur. Then we applied the framework to an actual case study concerning whether to feed elk over the winter in the Greater Yellowstone Area. To develop the framework, we combined concepts from decision analysis, political and institutional analysis, and public choice economics. The intent is to assist decision makers and stakeholders by developing a methodology for formally incorporating stakeholders' objectives and influence into the resource management planning process and to predict the potential success of rent-seeking activity (interest groups trying to gain the upper hand) based on stakeholder preferences and level of influence. We interviewed 30 stakeholder groups in person with three different surveys. We used the Analytical Hierarchy Process (AHP) along with a political science model to assess what types of political and resource power groups had and what types of power they thought would matter most in influencing decisions. We also used the AHP to determine weighted preferences for different policy outcomes. Combining this information, we predicted the level of support and conflict for all relevant policy decisions, and we identified who would support or oppose each decision.

**Keywords:** Decision Analysis; Analytical Hierarchy Process; Stakeholder influence; Stakeholder preferences; Public Choice

## 1. INTRODUCTION

In order to make efficient decisions, managers must incorporate the opinions and values of the involved stakeholders as well as understand the complex institutional constraints and opportunities that influence the decision-making process. Involved federal, state, local, private and public stakeholder groups have diverse values and preferences about the use and management of public resources. Underlying institutional factors give certain stakeholders a greater level of influence over the policy outcome. How stakeholders use their influence can greatly effect the time, effort and costs of the decision making process. The overall result of an individual stakeholder or stakeholder group's influence on a negotiation will depend both on their relative power and their level of conviction for a particular outcome.

Many tools have been developed to facilitate group negotiation and decision-making. Decision analysis

models such as the Analytical Hierarchy Process (AHP) are commonly used to prioritize the goals and objectives of stakeholders' preferences for resource planning by formally structuring conflicts and assisting decision makers in developing a compromised solution (Forman, 1998). Institutional models such as the Legal Institutional Analysis Model (LIAM) have been used to describe the organizational rules of behavior and the institutional boundaries constraining the management decision (Lamb et al., 1998). While some stakeholders will not be able to effectively influence the outcome under the existing institutional constraints, public choice models have been used to predict the potential success of rent-seeking activity (spending additional time and money to exert political pressure) to change the political rules (Becker, 1983).

While these tools have been successful at addressing a certain piece of the natural resource decision making process, their use in isolation is not

enough to fully depict the complexities of the physical and biological systems with the rules and constraints of the underlying economic and political systems. Often this type of information is not understood until after the decision has been made. We combined concepts from decision analysis, political and institutional analysis, and public choice economics to develop an institutional framework that predicts stakeholders' influence and preferences in the resource management decision-making process before the stakeholder meetings actually occur. Knowing stakeholders' preferences for management outcomes, what the institutional system looks like, and the opportunities for rent seeking allows for a more complete understanding of what influences the management decision.

### 1.1 Case Study

The U.S. Fish & Wildlife Service (FWS) and the National Park Service (NPS) are preparing a management plan for bison and elk inhabiting the National Elk Refuge (NER) and Grand Teton National Park (GTNP) near Jackson Hole, Wyoming. These animals are part of the bison and elk herds in Jackson Hole, one of the largest concentrations of free-ranging bison and elk in the world. In 2001, there were 13,500 elk in the Jackson elk herd, with over 7,000 animals wintering on the NER. When deep snows cover the vegetation or the vegetation has been eaten by the elk, the FWS provides supplemental feed in the form alfalfa hay pellets on the NER. The population of the Jackson bison herd has been increasing rapidly from 50 animals in 1980 to over 650 in 2002 as the herd discovered the supplemental feed distributed for elk on the NER. The winter feed program at the NER artificially concentrates the elk and bison, thereby increasing the transmission and frequency of several diseases including brucellosis. Because the bison and elk herds migrate across several jurisdictional boundaries--the National Elk Refuge, Grand Teton and Yellowstone National Parks, the Bridger-Teton National Forest (BTNF), and state and private lands--the FWS and NPS seek a cooperative effort among federal and state agencies and other stakeholders to develop a coordinated approach for managing the Jackson bison and elk herds. A range of alternatives for managing the bison and elk herds in the project area will be developed in an Environmental Impact Statement (EIS). The EIS must address the politically sensitive issues of habitat management, disease management, winter feeding and hunting programs related to the NER and GTNP.

## 2. PROCEDURES

To collect the information needed to construct the institutional framework, we interviewed 30 stakeholder groups in person with three different surveys representing: agricultural and ranching interests; hunting and outfitting; businesses involved with tourism; environmental and wildlife conservation; animal rights; the research and education community; Native American tribes; and federal, state, and local government officials. We used an AHP survey to determine weighted preferences for different policy outcomes. We used a second AHP survey along with a political science model survey to assess what types of political and resource power groups had and what types of power they thought would matter most in influencing decisions.

Building on a traditional welfare model (Bromley, 1989; Griffin, 1991), Rhodes and Wilson (1995) illustrated the difficulties surrounding the resource planning process when there are conflicts between alternative property rights. Following Rhodes and Wilson (1995), the production possibilities frontier (PPF), PPF\* in Figure 1 represents the technically efficient combinations of two types of land use services that can be produced using available

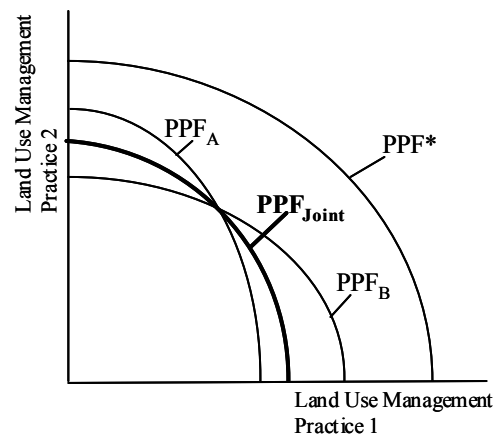

**Figure 1.** Property Rights in a Natural Resource Management Planning Process.

resources in the absence of transaction costs. The PPF has two management objectives with many alternative combinations of each objective possible along the curve. Two management objective proxies, Land Use Management Practice 1 and Practice 2, represent the multiple objectives associated with each resource management objective. The assumption of diminishing marginal returns creates a bowed PPF because every alternative offers some of each land use management practice objective.

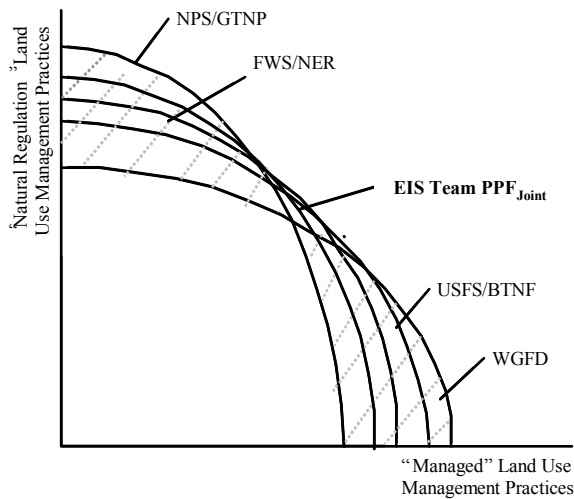

**Figure 2.** Elk & bison management PPF by agency.

Transaction costs can include the cost of information gathering, establishing a bargaining position, public hearings, negotiation, compromise, imperfect information, and litigation (Griffin, 1991; Rhodes and Wilson, 1995). Transactions costs associated with different property rights shift the PPF inwards to  $PPF_A$  for the property right of Agency A and  $PPF_B$  for Agency B.

For the Jackson Bison and Elk Management planning process, the property rights are held by the land management agencies on the EIS planning team (Figure 2). Current environmental laws and regulations as well as each land management agency's mandated mission, creates differing degrees of property rights (production possibilities) over the management of the Jackson herds. While the NPS is required to manage more for the "natural regulation" preservation objectives of resources, the multiple-use mandate of the USFS requires a more "managed" use that includes several types of resource uses and user groups. For example, recreational elk and bison hunting are permitted on the BTNF while only a restricted number of elk reduction hunting permits for population control purposes are issued for the GTNP and NER.

Given the anticipated level of involvement by each agency, the EIS PPF is conceptualized as a combination of the production possibilities that are allowed by the GTNP and NER and to a lesser extent, the BTNF and the Wyoming Game and Fish Department (WGFD) (Figure 2). The mandates, environmental regulations, and current budget allocations of GTNP, NER, BTNF, and WGFD will restrict the boundary and location of the EIS PPF curve (to the dashed lines area). It is assumed that there is an agreement, such as the National Environmental Policy Act (NEPA), that defines the ground rules between planning team agencies mandates and missions. The actual placement of the

joint EIS planning team PPF curve is a combination of all planning team agencies PPFs (EIS Team  $PPF_{Joint}$  in Figure 2).

## 2.1 Stakeholder Preferences

Stakeholders that do not have property rights will not have leverage in determining the actual placement of the  $PPF_{Joint}$  curve. After the  $PPF_{Joint}$  curve boundaries have been legally established, it is assumed that the stakeholder groups involved in the public participation process can influence the position of the decision outcome along the  $PPF_{Joint}$  curve. Amounts of land use services exterior the  $PPF_{Joint}$  boundary are not achievable without social reform and will not be considered.

Because of the complexities and different issues surrounding managing bison and elk for disease, feeding, and hunting, the PPF and management alternatives were separated for bison and elk management activities. To determine stakeholder placement along the elk and the bison  $PPF_{Joint}$ , each stakeholder completed an AHP pairwise comparison survey that measured their weighted preferences for the elk and bison management objectives. The elk management strategies hierarchy and example AHP preference weights are shown in Figure 3.

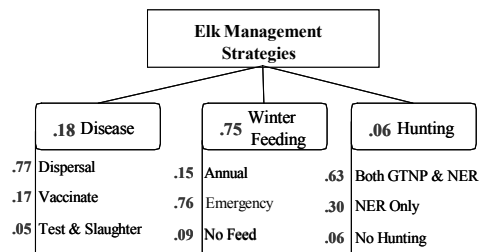
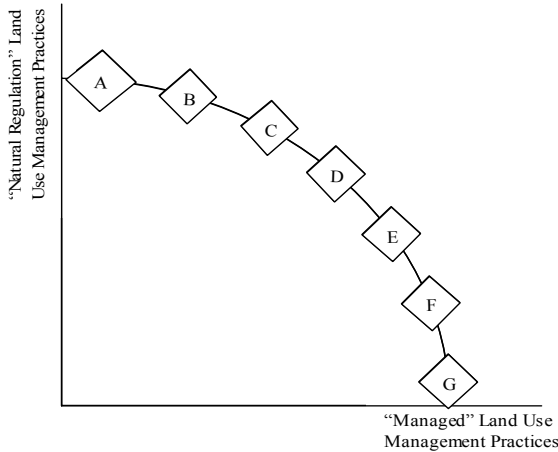

**Figure 3.** Elk management strategies hierarchy and example AHP preference weights.

Conceptually, the  $PPF_{Joint}$  curve will have a limited number of management alternatives that can be produced. Hypothetical management alternatives were created to show possible outcomes for the two objective proxies, natural regulation and managed land use management practices (Figure 4).

Indexes were developed in order to match stakeholders' preference weightings with the placement of the management alternatives on the  $PPF_{Joint}$  curve. Because it was possible to combine management options that are considered natural

| Management Strategies  | Extreme Natural | Moderate Natural | Moderate Managed | Extreme Managed |   |   |   |
|------------------------|-----------------|------------------|------------------|-----------------|---|---|---|
| Disease                |                 |                  |                  |                 |   |   |   |
| Dispersal              | X               | X                | X                | X               |   |   |   |
| Vaccinate              |                 |                  |                  | X               |   |   |   |
| Test & Slaughter       |                 |                  |                  | X               |   |   |   |
| Winter Feeding         |                 |                  |                  | X               |   |   |   |
| Annual                 |                 |                  | X                | X               |   |   |   |
| Emergency              |                 |                  | X                | X               |   |   |   |
| No Feed                | X               | X                | X                |                 |   |   |   |
| Hunting                |                 |                  |                  |                 |   |   |   |
| Both GTNP & NER        |                 | X                | X                | X               |   |   |   |
| NER Only               |                 | X                | X                |                 |   |   |   |
| No Hunting             | X               |                  |                  |                 |   |   |   |
| Placement on PPF Curve | A               | B                | C                | D               | E | F | G |



**Figure 4.** Placement of management alternatives along the PPF<sub>Joint</sub>.

with options that are considered managed, each management alternative has a natural and a managed index score to represent the amount of natural regulation and managed land use services included in each alternative (Figure 5). Alternative A, contains the most natural regulation management options with the highest possible amounts of dispersal, no winter-feeding, and no hunting. Alternative G contains the most managed management options with the highest possible amounts test & slaughter, annual winter feeding, and hunting on both the refuge and the park. Alternatives B through F contain combinations of natural and managed management options.

The tangency slope of each stakeholder's preference index score provided the associated preference ratio between natural and managed management options. Each stakeholder's

| Preference Index | Natural | Managed |
|------------------|---------|---------|
| Dispersal        | 100%    | 0%      |
| Vaccinate        | 25%     | 75%     |
| Test & Slaughter | 0%      | 100%    |
| Annual           | 0%      | 100%    |
| Emergency        | 40%     | 60%     |
| No Feed          | 100%    | 0%      |
| Both GT/NER      | 0%      | 100%    |
| Only NER         | 25%     | 75%     |
| No Hunting       | 100%    | 0%      |

**Figure 5.** Preference index percentages.

preference ratio tradeoff determines his or her placement on the PPF<sub>Joint</sub> curve. Because the AHP allows stakeholders to choose any amount of each management option, some stakeholders fell between the alternatives.

## 2.2 Stakeholder Influence

Decision-making activities for federal land management take place within established boundaries provided by statute, legal precedent and tradition. Institutional analysis provides an assessment of these boundaries by studying the legal, political, and administrative processes through which public policy decisions are made (Ingram, 1984). The Legal Institutional Analysis Model (LIAM) is a computerized model that examines the political aspects of a natural resource conflict (Lamb et al., 1998). The model enables the various stakeholders involved to understand the nature of the issue at hand as well as evaluate the roles, needs, and power of organizations involved in a natural resource conflict.

We had stakeholders complete the LIAM survey in order to assess the types of political roles and power of their organization for the elk and bison planning process. We used a second AHP survey to have stakeholders weight the LIAM role and power types they considered to be the most in influencing the decision process. Results from these surveys were combined to determine the political influence of each stakeholder group.

## 2.3 Rent Seeking

Because the allocation of scarce resources necessarily excludes or limits some types of resource use, stakeholders have an incentive to compete for a larger share of the allocation through the political process. Rent seeking is the activity of influencing the political process by means of lobbying, media campaigns, public hearings, and litigation to obtain favorable results or avoid unfavorable ones. Rent seeking has important welfare implications because the transactions costs associated with individual or group efforts to maximize their own utility can generate social waste rather than social surplus (Buchanan et al., 1980).

There will be certain issues in the decision (hunting, feeding, and vaccination) that certain stakeholders are more willing to fight over if the outcome looks unfavorable. After the planning team selects a Draft EIS preferred alternative, if the outcome is not close to the preferences of a given stakeholder,

that stakeholder can increase its rent seeking activities to try to force a more favorable outcome. How much rent seeking actually happens depends on the degree of importance of each issue to a stakeholder (**the policy benefit**), how different the draft alternative is to their preferred alternative (**the policy cost**), what abilities they have to influence the outcome, and the level of rent seeking by other stakeholder groups. To estimate the level of rent seeking by each stakeholder, results from the AHP management preferences survey were used to estimate the policy benefit and policy cost of the management alternatives.

### 3. RESULTS

Results from the AHP management preferences survey are presented in Table 1. The overall categories of disease, winter feeding, and hunting sum to one. The management options within each category also sum to one.

| Elk Management Strategies | NPS         | FWS         | USFS        | WGFC        | Hunting Group (WHA) | Environmental Group (SC) |
|---------------------------|-------------|-------------|-------------|-------------|---------------------|--------------------------|
| <b>DISEASE</b>            | <b>0.54</b> | <b>0.18</b> | <b>0.19</b> | <b>0.04</b> | <b>0.33</b>         | <b>0.23</b>              |
| Dispersal                 | 0.94        | 0.77        | 0.98        | 0.01        | 0.05                | 0.98                     |
| Vaccinate                 | 0.05        | 0.17        | 0.01        | 0.98        | 0.80                | 0.01                     |
| Test & Slaughter          | 0.01        | 0.05        | 0.01        | 0.01        | 0.15                | 0.01                     |
| <b>WINTER FEEDING</b>     | <b>0.08</b> | <b>0.75</b> | <b>0.76</b> | <b>0.21</b> | <b>0.33</b>         | <b>0.69</b>              |
| Annual                    | 0.07        | 0.15        | 0.17        | 0.78        | 0.98                | 0.16                     |
| Emergency                 | 0.90        | 0.76        | 0.79        | 0.21        | 0.01                | 0.77                     |
| No Feed                   | 0.04        | 0.09        | 0.05        | 0.00        | 0.01                | 0.08                     |
| <b>HUNTING</b>            | <b>0.38</b> | <b>0.06</b> | <b>0.05</b> | <b>0.75</b> | <b>0.33</b>         | <b>0.08</b>              |
| Both GTNP & NER           | 0.43        | 0.63        | 0.33        | 0.95        | 0.98                | 0.01                     |
| Only NER                  | 0.43        | 0.30        | 0.33        | 0.04        | 0.01                | 0.98                     |
| No Hunting                | 0.14        | 0.06        | 0.33        | 0.00        | 0.01                | 0.01                     |

**Table 1.** Results from the AHP management preference survey.

To determine stakeholder placement along the PPF<sub>Joint</sub>, the preference index percentages (Figure 5) were combined with each stakeholder's management option preference weights. Placement results are shown in Figure 6.

The results from the LIAM survey measuring each stakeholder's level of political role and power were combined with the results from the second AHP survey measuring the importance of the role and power types in influencing the decision process. This resulted with Alternative E as being the most likely preferred Draft EIS alternative for elk management given the current level of stakeholder political influence. Given that the management options associated with Alternative E are a combination of natural regulation (dispersal and emergency feeding) and managed (vaccination and hunting) management options suggests that the resulting outcome will be a negotiated solution. This indicates that no one or group of stakeholders has enough power or role characteristics to

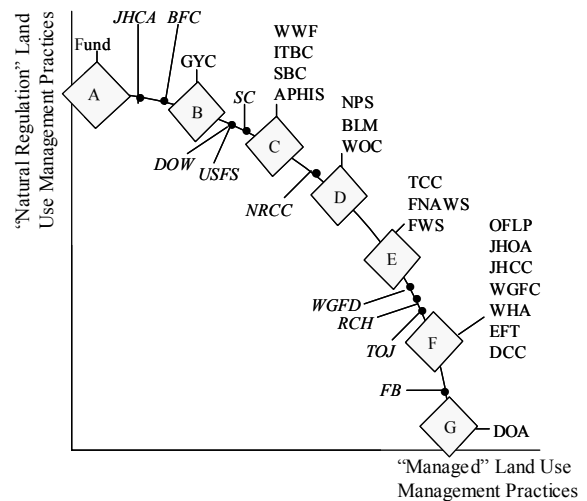

**Figure 6.** Stakeholder Placement along the PPF<sub>Joint</sub>. (Acronyms represent Stakeholder Groups)

drastically change the outcome. In order to alter the outcome, a stakeholder would need an exceptionally high level of influence or would have to litigate to get the property rights changed.

The results from the AHP management preferences survey were used to predict rent seeking behavior. Table 2 provides an example of how stakeholder rent seeking scores were calculated. The importance weight each stakeholder gave to the overall management, forage management, and hunting was used to represent the **policy benefit** of each alternative. For example, the preferred elk management strategies for the environmental group, SC, are dispersal (98%), emergency feeding (77%), and hunting only on the NER (98%) (Table 1). The overall category importance weights for the SC are 23% for disease, 69% for winter feeding, and 8% for hunting. Even though the SC has a strong preference for hunting only on the NER, the overall issue of hunting is not as important as the disease and winter feeding issues.

| Elk Management       | Draft EIS Alt. (E) | Environmental Group (SC) |                        |                              | Hunting Group (WHA) |                        |                              |
|----------------------|--------------------|--------------------------|------------------------|------------------------------|---------------------|------------------------|------------------------------|
|                      |                    | Preferred Alt.           | Policy Cost (# points) | Rent Seeking (Benefit* Cost) | Preferred Alt. (E)  | Policy Cost (# points) | Rent Seeking (Benefit* Cost) |
| <b>DISEASE</b>       |                    |                          |                        | <b>0.23</b>                  |                     |                        | <b>0.33</b>                  |
| Dispersal            | <b>0.70</b>        | 0.98                     | 0.28                   | 0.06                         | 0.05                | 0.65                   | 0.22                         |
| Vaccinate            | <b>0.20</b>        | 0.01                     | 0.19                   | 0.04                         | 0.80                | 0.60                   | 0.20                         |
| Test & Slaughter     | <b>0.10</b>        | 0.01                     | 0.09                   | 0.02                         | 0.15                | 0.05                   | 0.02                         |
| <i>Disease Total</i> |                    | <b>0.56</b>              |                        | <b>0.13</b>                  |                     | <b>1.30</b>            | <b>0.43</b>                  |
| <b>FEEDING</b>       |                    |                          |                        | <b>0.69</b>                  |                     |                        | <b>0.33</b>                  |
| Annual               | <b>0.21</b>        | 0.16                     | 0.05                   | 0.03                         | 0.98                | 0.77                   | 0.26                         |
| Sufficient           | <b>0.73</b>        | 0.77                     | 0.04                   | 0.03                         | 0.01                | 0.72                   | 0.24                         |
| No Feed              | <b>0.06</b>        | 0.08                     | 0.02                   | 0.01                         | 0.01                | 0.05                   | 0.02                         |
| <i>Forage Total</i>  |                    | <b>0.11</b>              |                        | <b>0.08</b>                  |                     | <b>1.54</b>            | <b>0.51</b>                  |
| <b>HUNTING</b>       |                    |                          |                        | <b>0.08</b>                  |                     |                        | <b>0.33</b>                  |
| Both GT/NER          | <b>0.85</b>        | 0.01                     | 0.84                   | 0.07                         | 0.98                | 0.13                   | 0.04                         |
| Only NER             | <b>0.13</b>        | 0.98                     | 0.85                   | 0.07                         | 0.01                | 0.12                   | 0.04                         |
| No Hunting           | <b>0.02</b>        | 0.01                     | 0.01                   | 0.00                         | 0.01                | 0.01                   | 0.00                         |
| <i>Hunting Total</i> |                    | <b>1.70</b>              |                        | <b>0.14</b>                  |                     | <b>0.26</b>            | <b>0.09</b>                  |
| <b>Total</b>         |                    |                          | <b>2.37</b>            | <b>0.34</b>                  |                     | <b>3.10</b>            | <b>1.03</b>                  |

**Table 2.** Calculating stakeholder rent seeking scores.

The actual point difference between a stakeholder's preferred management strategies preference weighting scores and the preference weighting scores of the Draft EIS preferred alternative (Alternative E) were used to determine the **policy cost** for each stakeholder. The policy cost for the SC will be the point difference between Alternative E and SC's preferred alternative, between Alternative B and C. By multiplying the magnitude of policy benefit for each of the overall management categories by the policy cost of the management options within the management category, a rent seeking score can be calculated for each stakeholder (Table 2). For the Draft EIS Alternative E, the hunting group, WHA, policy cost and rent seeking scores are higher than the SC (Table 2). The SC has the highest policy benefit for the winter feeding issue and the Draft EIS alternative is close to the SC's preferred alternative resulting in a low policy cost. The SC has a high policy cost on the hunting option but a low policy benefit resulting in a low overall rent seeking score. The WHA gave equal policy benefit to all three issues. The WHA's preferred alternative is close to the Draft EIS alternative for the hunting option but not for the winter feeding and disease management options resulting in a high overall policy cost and rent seeking score. It is interesting to note that even though the SC has a lower rent seeking score, the SC is actually farther away (Alternative C) from the Draft EIS Alternative (E) than the WHA (Alternative F) on the the PPF<sub>Joint</sub> curve (Figure 6).

Summing the rent seeking scores of all stakeholders results in total rent seeking scores of 38.2 for Alternative A, 33.7 for Alternative B, 24.0 for Alternative C, 26.3 for Alternative D, 21.5 for Alternative E, 24.1 for Alternative F, and 35.0 for Alternative G. Out of the seven possible management outcomes, the Draft EIS Alternative (E) will have the least amount of rent seeking and thus, it is the best negotiated solution. Alternative A would be the most highly contested outcome. Of the total rent seeking for Alternative E, 27% of the effort will be spent on issues dealing with the disease management option, 54% on the feeding option, and 19% on hunting. The highest rent seeking stakeholder scores are for stakeholders that had strong preferences (had a high policy benefit score) for the no winter feeding management option.

#### 4. CONCLUSIONS

Managers must consider all opinions when they develop management policies. By constructing an institutional framework, we were able to predict the level of support and conflict for all relevant policy

decisions, and identify who would support or oppose each decision. Results show that for a collaborative decision-making process, there will be a negotiated solution with the outcome landing somewhere in the middle. Knowing stakeholders' preferences for management outcomes, what the institutional system looks like, and how stakeholders are likely to react to the different management options **before** the decision is made can assist and improve the decision makers' understanding of the decision process and lead to a collaborative decision that includes the preferences of all stakeholders. This significantly increases the overall efficiency of the natural resource decision-making process and reduces the risk of having the process sent into litigation.

Even though the Draft EIS has not been released, we have tested our results with the stated intentions stakeholders have made at recent public meetings and through letters submitted to the EIS planning team and local newspapers. We have found that our results accurately predict the issues each stakeholder will fight over as well as the issues where compromise can be reached.

#### 5. REFERENCES

- Becker, G.S., A theory of competition among pressure groups for political influence, *The Quarterly Journal of Economics*, XCV111 (3), 371-400, 1983.
- Bromley, D.W. *Economic Interests and Institutions*, Oxford, Basil Blackwell, 1989.
- Buchanan, J.M., R.D. Tollison, and G. Tullock. *Toward a Theory of the Rent-Seeking Society*. Texas A&M University Press, College Station, 1980.
- Forman, E. *Decision By Objectives*. McLean VA: Expert Choice Inc. 1998.
- Griffin, R.C., The welfare analytics of transaction costs, externalities, and institutional choice, *American Journal of Agricultural Economics*, 73, 601-614, 1991.
- Ingram, H. M., Mann, D.E., Weatherford, G.D., and H.J. Cortner, Guidelines for improved institutional analysis in water resources planning, *Water Resources Research*, 20(3), 323-334, 1984.
- Lamb, B. L., J. G. Taylor, N. Burkardt, P. D. Ponds. A policy model to initiate environmental negotiations: three hydropower workshops, *Human Dimensions of Wildlife*, 3(4), 1-17, 1998.
- Rhodes, T.C., and P.N. Wilson, Sky islands, squirrels, and scopes: the political economy of an environmental conflict, *Land Economics*, 71(1), 106-121, 1995.